

Development of a Robust Dynamic Damage Control Simulator

MCP Dissanayake^{1#} and PMKC Chandimal²

¹ Department of Marine Engineering, Faculty of Engineering, General Sir John Kotelawala Defence University, Sri Lanka

² Department of Mechanical Engineering, Faculty of Engineering, General Sir John Kotelawala Defence University, Sri Lanka

#dissanayakemcp@kdu.ac.lk

Abstract— The art of ‘Damage Control’ has been part of a seafarer’s professional expertise for time immemorial. The utility of effective damage control as well as the disastrous consequences of lack of it, in modern Naval combat, was once again very painfully reminded during the Falklands War in 1982. Consequently, the discipline of ‘Damage Control’ underwent some of the most radical changes as part of the lessons learnt exercise at the end of this war. The resultant overhaul of the damage control system, onboard Naval ships, envisaged wide-ranging improvement in many facets of naval warfare ranging from basic outlook towards damage control to rudiments of ships design itself. However, the most significant part of this process was to train the basic human response, in the face of a catastrophe, from essentially a crisis management exercise to a systematic application of resources. Needless to say extensive and realistic training forms the cornerstone of this evolution of transforming damage control from the chaotic response into a symphony of ‘right actions’ in this endeavour, while the technology bridged the gap between available and desirable, simulators helped in recreating realistic scenarios under a controlled environment to extract maximum benefits of training (Valera and Soares, 2007).

Keywords— **Damage Control, Battle Simulation, Crew Competency**

I. INTRODUCTION

The Damage Control Simulator (DCS) is fundamentally a training method that simulates a realistic and stressful, nevertheless a controlled environment for crew training in ship damage control and repair in various damage scenarios (Bulitko and Wilkins, no date b). Further, DCS can be utilized for crew training in both war and peace times equally. Subsequently, to encompass the damage and save the vessel, the crew needs to be able to respond to the threat with efficiency, expertise and confidence gained from training in similar situations. The realistic damage scenarios and crisis generated in the DCS contributes invaluable in driving away fear among the trainees and in improving team building traits, thereby preparing them for unforeseen hardships and emergencies at sea.



Figure 1: Damage control simulator, Malaysian Navy
Source: (*Damage Control Training unit — Protankgrüpp*)

Static Damage Control Simulator

The erstwhile static damage control simulator was a fixed structure simulating a two-deck arrangement of a ship with usual ship fittings to simulate ship-like experience while performing damage control exercises. Even though this been a useful tool in training onboard crew members, it lacked fundamentally in its ability to simulate rolling and pitching motion of a ship during the exercises. The importance of simulating ships motion during any shipborne simulation exercise cannot be overemphasized (Bulitko and Wilkins, no date a). However, in the case of a damage control exercise, it assumes even more criticality because unlike other facets of training which can be replicated at sea, a realistic damage control exercise can only be conducted ashore and therefore simulation of ships motion gains paramount importance to infuse reality in the conditions. Naval and Maritime Academy has not lagged in assimilating this evolving discipline and had started imparting systematic training in damage control to naval personnel quite early. The pioneering effort in the direction of damage control simulation was made by Cdr VC Munundradassa (Retd), who designed and built a static damage control simulator in 1992 and installed it at the Engineering School. Subsequently, this static damage control simulator was shifted to its present location at Nuclear, Biological, Chemical and Defence (NBCD) School in the year 2000 when a separate school was

established exclusively for firefighting and damage control training.

II. METHODOLOGY



Figure 2: Static Damage Control Simulator

In order to enhance the realism in the damage control environment simulated at NBCD School and thus the training value of damage control training, the erstwhile static damage control simulator has now been transformed into a dynamic simulator with innovative application of available resources and ingenious efforts by the staff of Naval and Maritime Academy. These modifications transforming static simulator into dynamic simulator were completed on 08th August 2006 and subsequently, the simulator was christened as “Mahasen”. With these modifications, the static simulator has now been mounted on a pivot arrangement and incorporated with a tilting mechanism to induce rolling motion to the entire structure. As per the design calculations, the desired 15 degrees of a roll of the structure is achieved by a 1.1 kW electric motor and a drive mechanism of a worm wheel and shaft assembly. Apart from this major modification, the simulator has also been modified to create more realistic conditions in terms of the acoustic and visual environment inside the simulator. After the modification, the two compartments of the simulator can be flooded with water at a rate of 25 tons per hour providing the capability to completely submerge the entire simulator within approximately 12 minutes. With this infrastructure, various battle damages like leaks, high-pressure pipe bursts, bulkhead damaged can be simulated. Apart from the damage simulation under 15 degree rolling conditions, following environmental conditions can also be concurrently simulated to provide realistic situations during exercises:

- i. Total darkness to simulate a power failure.
- ii. Air Conditioning to simulate actual ship like environmental conditions.
- iii. Smoke generation to simulate a fire incident.
- iv. Explosion and other sounds to simulate battle damages.

A. Design Procedure

In this design process, 1.1 kW, 1500 rpm three-phase motor is selected as a power source. Then, the motor is connected to the gearbox by ‘V’ belt. The gearbox can withstand 1.1 kW power, by using only one speed, of 625 rpm. A sliding mesh is encompassed with this design gearbox and input gearwheel is fixed to the shaft, while pinion gearwheels are boxed up with a gear block. The gearbox consists of 02 gear wheels, 02 shafts and bearings.

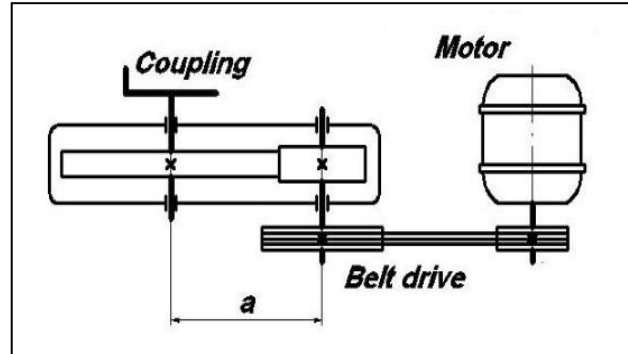

Figure 3: Sketch of Gear Drive

As per the dimensions of Damage control simulator, we neglected geometry of internal compartments in calculating Moment of Inertia of the entire structure.

Design of motor

Considering the resources available, motor with following specifications has been selected.

Table 1. Specifications of system

System Specification	Value
Moment of Inertia, I	450.4 kgm ²
Torque, T	11.26 Nm
Actual power required, P ₁	1.083 kW
Belt drive efficiency	85%
Gearbox efficiency	80%
Selected motor	5.5 kW, 3φ, 1500 rpm

Design of Belt drive and gearbox

Single belt drive is selected to transmit the power to gear box and two gear wheels selected for reduction of speed

Table 2. Description of belt drive and gear box

Description of Belt drive and Gearbox	Value
Speed ratio	2.4
Input drive speed	625 rpm
Required speed for simulator	125 rpm
Gear ratio, G	5.0
Module, m	3 mm
No of teeth in pinion	20
No of teeth in gear	100
Diameter of pinion	60 mm
Diameter of gear	300 mm

Shaft Design

Considering maximum bending moment and torque,

Input shaft diameter, $D_1 = 25$ mm

Output shaft diameter, $D_2 = 30$ mm

Material: Mild steel

Selection of Bearings

Bearings subjected to radial loads,

$$P = XF_r$$

$X = 1$ for deep groove ball bearing

Working hours per day = 2 hours

Life of bearing = 5 years

Table 3. Bearing selection details

Description	For Driving Shaft	For Driven Shaft
Diameter, d	25 mm	30 mm
Dynamic load, P	5.2×10^3 N	4.33×10^3 N
Life of bearing, L_{10}	136.875 rev	27.375 rev
Dynamic load carrying capacity, C	26800 N	13042 N
Catalogue C value	35800 N	19500 N
Designated Deep groove ball bearing	6305	6206
Outer diameter	80 mm	62 mm
Axial width	21 mm	16 mm

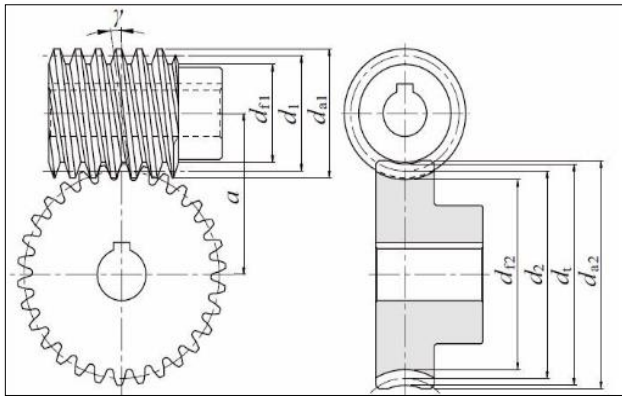

Figure 4: Cylindrical Worm Gear Pair

B. Utility for Training

‘Mahasen’ can be utilized for training sixteen trainees under the supervision of three qualified instructors at any given time. The realistic damage conditions created by the simulator are of enormous training value as they inculcate team spirit and remove fear from the mind of the trainees, conditioning their responses into orchestrated teamwork in the face of rapidly deteriorating conditions. The practised response of all personnel in the face of battle damage recreated under the safety of a controlled environment will go a long way in preparing personnel for the actual eventualities at sea. ‘Mahasen’ is also being utilized to train personnel of the fleet apart from the trainees of the academy

and is contributing immensely to the overall preparedness of our Navy.

III. CONCLUSION

This DCS is purely utilized to train Sri Lanka Navy personnel, who are assigned on board ships in damage control and repair in different damage scenarios. Further, this training was immensely helped to remove psychological fear, developed leadership skills, enhanced communication skills, team building support and experienced in handling war casualties.

It is recommended to incorporate pitching movement by mechanical means along with rolling motions to enhance the more realistic scenario for crew onboard vessels.

I. References

Bulitko, V. V and Wilkins, D. C. (no date a) *Damage Control Domain: Using Petri Nets for Intelligent Scheduling*.

Bulitko, V. V and Wilkins, D. C. (no date b) *Minerva-DCA: An Intelligent Agent for Ship Damage Control*.

Damage Control Training unit — Protankgrup (no date). Available at: <http://protankgrup.com/damage-control-training-unit> (Accessed: 30 July 2020).

Valera, J. M. and Soares, C. G. (2007) ‘A virtual environment for decision support in ship damage control’, *IEEE Computer Graphics and Applications*. IEEE Computer Society, 27(4), pp. 58–69. doi: 10.1109/MCG.2007.74.